

EXECUTIVE DESIGN SPECIFICATIONS - SYSTEM WITH RECESSED SIDE TRACK (V3)

(External Assembled View)

FOR ILLUSTRATION PURPOSES ONLY - NOT DRAWN TO SCALE

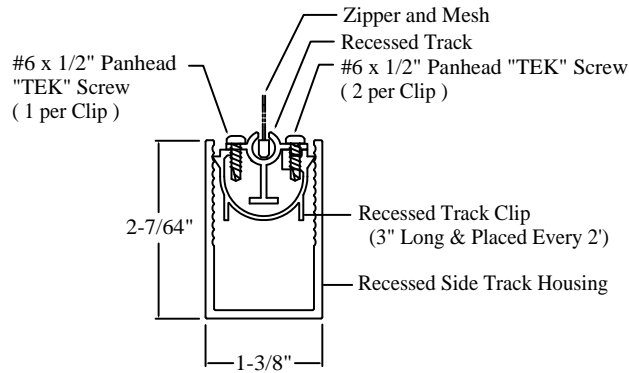

**CROSS SECTIONAL VIEW
OF THE FULLY ASSEMBLED
RECESSED SIDE TRACK (V3)**

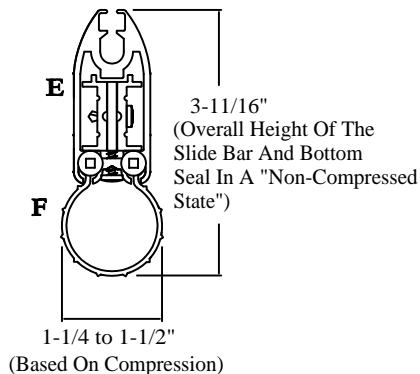
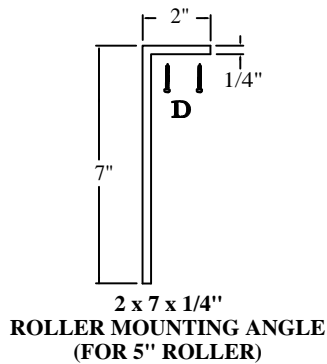
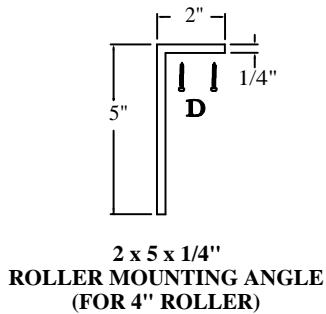

**CROSS SECTIONAL VIEW
OF THE
SLIDE BAR AND
4" BOTTOM SEAL**

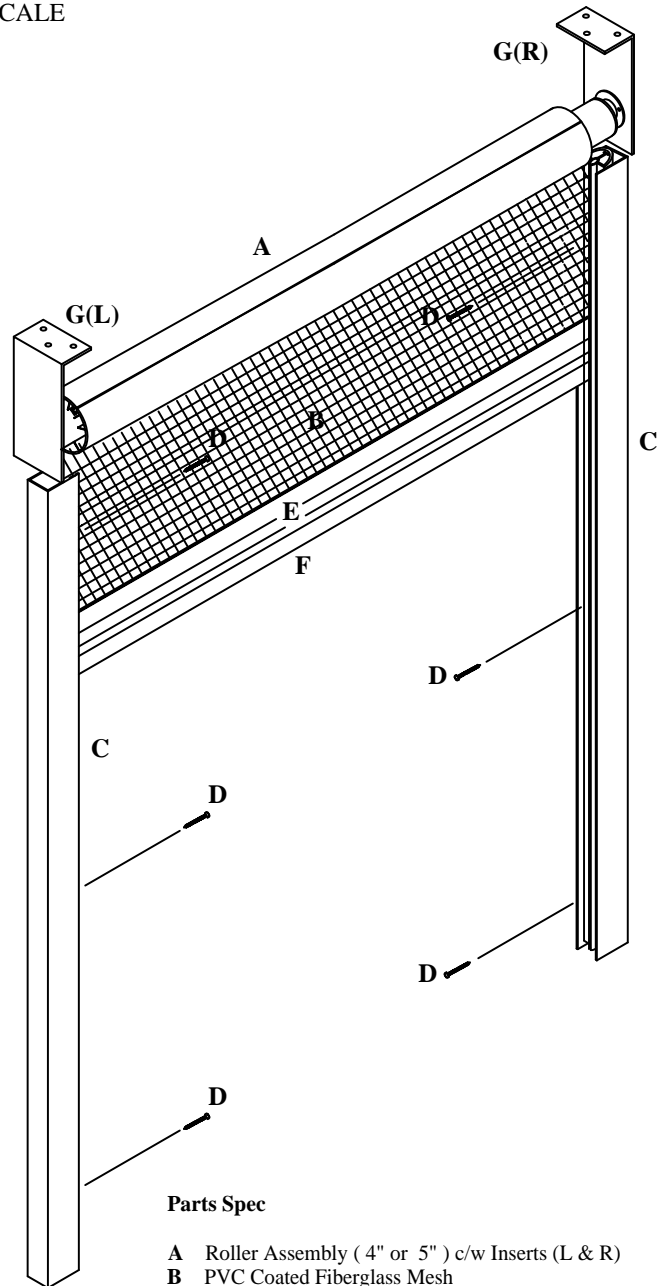

Parts Spec

- A** Roller Assembly (4" or 5") c/w Inserts (L & R)
- B** PVC Coated Fiberglass Mesh
or other - see Mesh Specifications
- C** Recessed Side Track Assembly (1-3/8"W x 2-7/64"D)
- D** #8 or #10 Corrosion Resistant Fastener
Type and length of screws may
vary depending on type of mounting surface
(Minimum of 3 per Side Track and Roller Mounting Angle)
- E** Slide Bar c/w Probe Assembly
- F** Bottom Seal - 4" Shown (Other options available)
- G** Roller Mounting Bracket
(2 x 5 x 1/4" or 2 x 7 x 1/4" - all 3-1/4" W)

All components are color matched except Mesh, Rivets, and Bottom Seal.
All fasteners are corrosion resistant. See "Fastener Reference Guide" for details.
For application sizes, refer to Size Tables.