

EXECUTIVE DESIGN SPECIFICATIONS - SYSTEM WITH STANDARD SIDE TRACK (V2A) (External Assembled View)

FOR ILLUSTRATION PURPOSES - NOT DRAWN TO SCALE

Parts Spec

- A Housing Assembly:
(5-1/2"W x 5-1/2"H or 7-1/8"W x 7-1/8"H)
- B #8 x 1" Corrosion Resistant Fastener (Color Matched)
3 Fasteners per End Cap
- C PVC Coated Fiberglass Mesh
or other - see Mesh Specifications
- D Standard Side Track (V2A) c/w Cover (1-3/4" W x 1-17/32" D)
- E #8 or #10 Corrosion Resistant Fastener
Type and length of screws may
vary depending on type of mounting surface
- F Slide Bar c/w Probe Assembly
- G Bottom Seal - 4" Shown (Other Options Available)
- H Mounting Surface

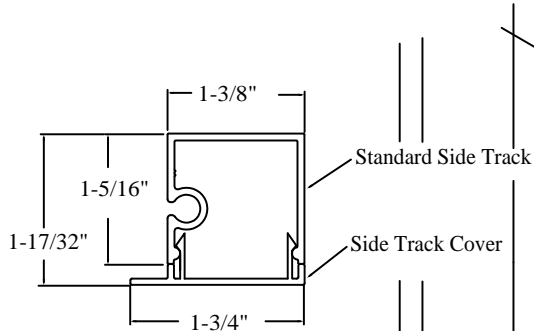

**CROSS SECTIONAL VIEW
OF THE
STANDARD SIDE TRACK (V2A)**

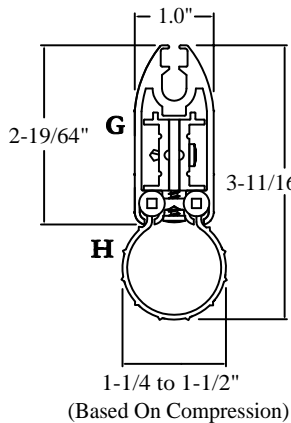

**CROSS SECTIONAL VIEW
OF THE
SLIDE BAR AND
4" BOTTOM SEAL**

(Overall Height Of The
Slide Bar And Bottom
Seal In A "Non-Compressed
State")

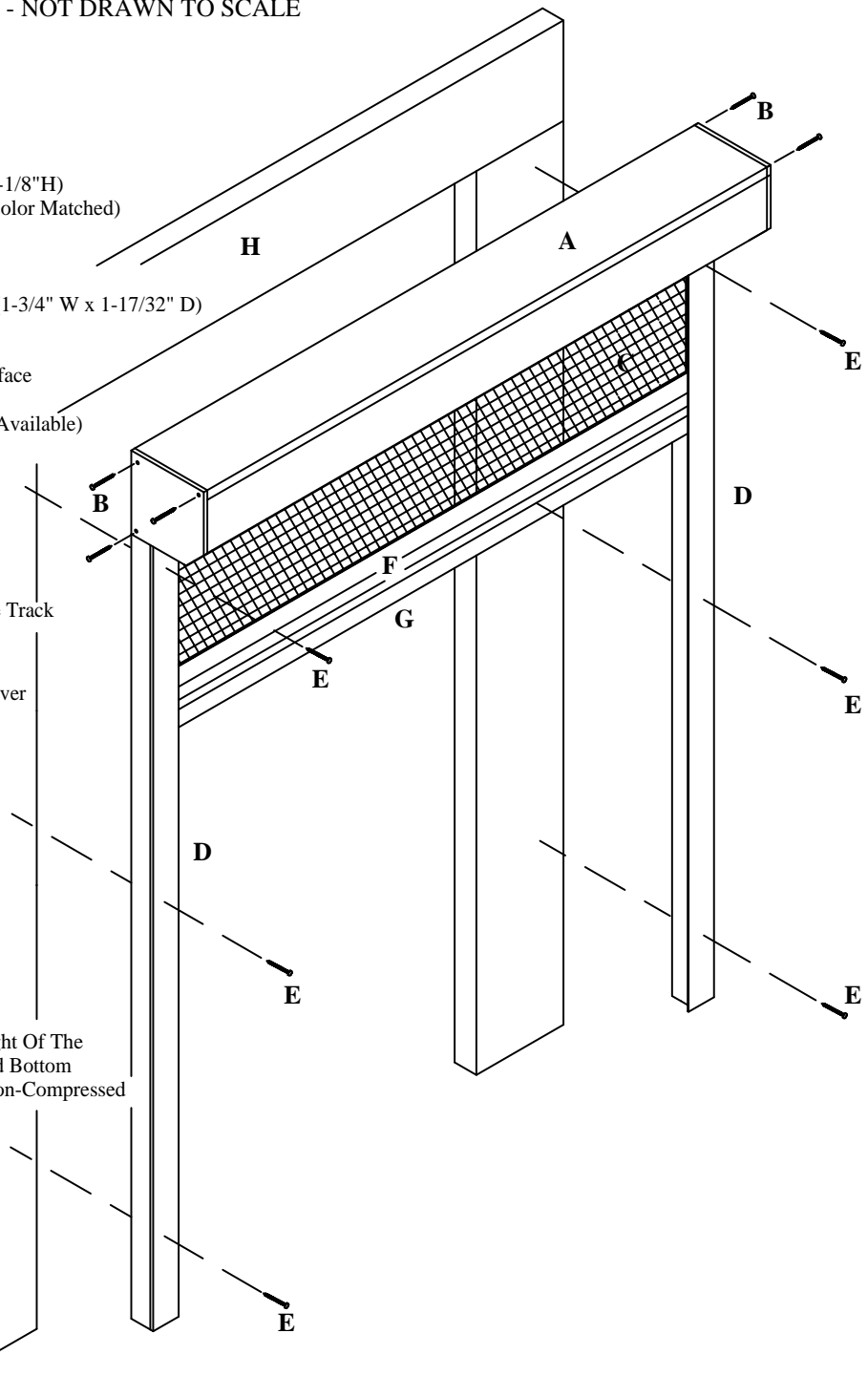

All components are color matched except Mesh and Bottom Seal.
All fasteners are corrosion resistant. See "Fastener Reference Guide" for details.
For application sizes, refer to Size Tables.