

# Phantom Door Design Specifications

## (External Assembled View)

For Illustration Purposes Only - Not Drawn to Scale

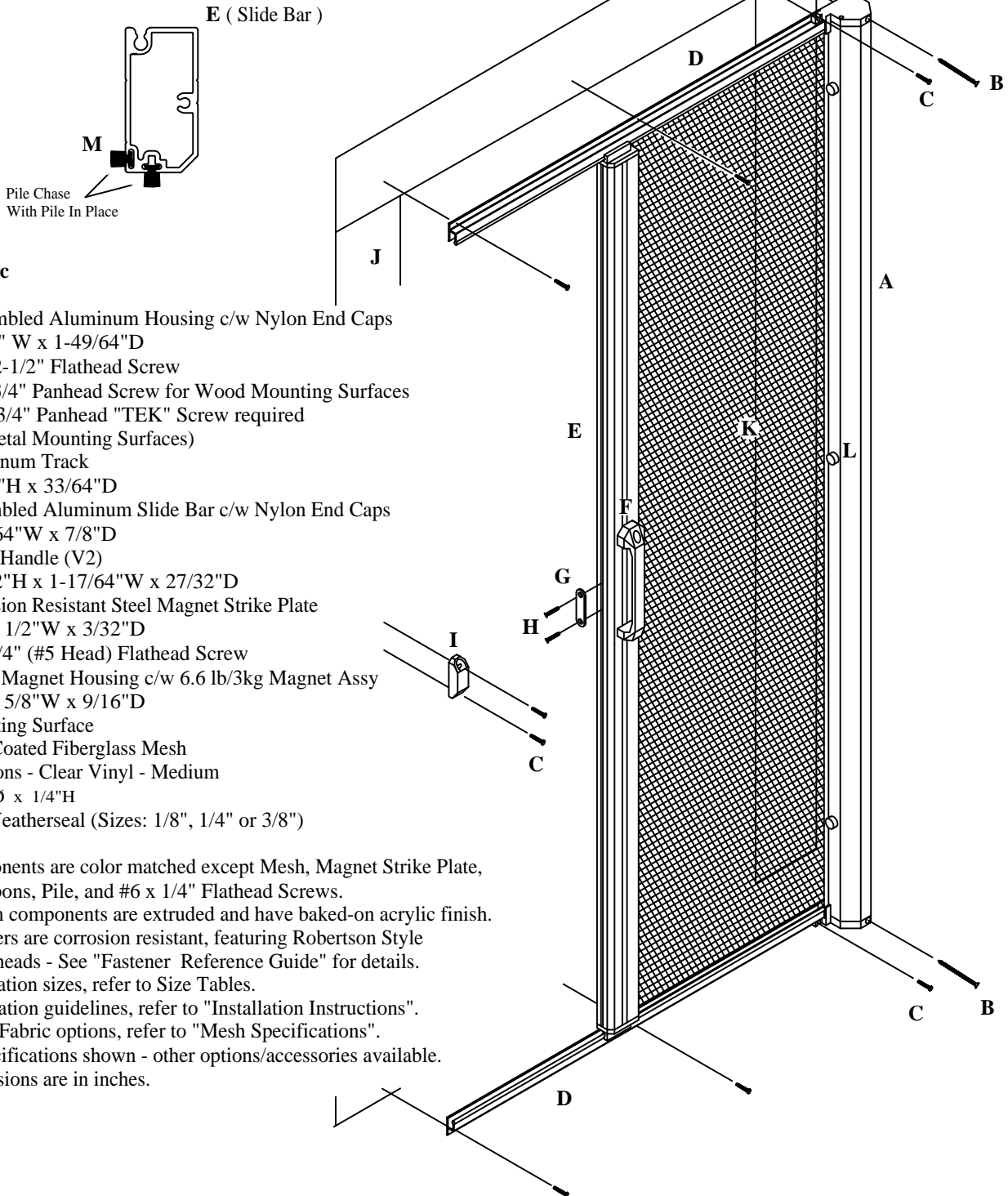

### Parts Spec

- A** Assembled Aluminum Housing c/w Nylon End Caps  
1-7/8" W x 1-49/64"D
- B** #8 x 2-1/2" Flathead Screw
- C** #6 x 3/4" Panhead Screw for Wood Mounting Surfaces  
(#6 x 3/4" Panhead "TEK" Screw required  
for Metal Mounting Surfaces)
- D** Aluminum Track  
15/16"H x 33/64"D
- E** Assembled Aluminum Slide Bar c/w Nylon End Caps  
1-47/64"W x 7/8"D
- F** Nylon Handle (V2)  
6-1/32"H x 1-17/64"W x 27/32"D
- G** Corrosion Resistant Steel Magnet Strike Plate  
2"H x 1/2"W x 3/32"D
- H** #6 x 3/4" (#5 Head) Flathead Screw
- I** Nylon Magnet Housing c/w 6.6 lb/3kg Magnet Assy  
2"H x 5/8"W x 9/16"D
- J** Mounting Surface
- K** PVC Coated Fiberglass Mesh
- L** Bumpons - Clear Vinyl - Medium  
1/2" Ø x 1/4"H
- M** Pile Weatherseal (Sizes: 1/8", 1/4" or 3/8")

All components are color matched except Mesh, Magnet Strike Plate, Bumpons, Pile, and #6 x 1/4" Flathead Screws.

Aluminum components are extruded and have baked-on acrylic finish.

All fasteners are corrosion resistant, featuring Robertson Style driverheads - See "Fastener Reference Guide" for details.

For application sizes, refer to Size Tables.

For installation guidelines, refer to "Installation Instructions".

For Mesh Fabric options, refer to "Mesh Specifications".

Basic specifications shown - other options/accessories available.

All dimensions are in inches.